

NEUSPEED®

P-FLO COLD AIR INTAKE FOR 1993-99 GOLF III / JETTA III 2.0L 8V

PART # 65.10.60 & 65.10.64

INSTALLATION INSTRUCTIONS

PARTS LIST:

- | | |
|-------------------------------|-----------------------|
| 1 – HEAT SHIELD | 2 – ¼” WASHER |
| 1 – AIR FILTER | 1 – PUSH FASTENER |
| 1 – MINI FILTER (IF EQUIPPED) | 1 – SHEET METAL SCREW |
| 2 – ¼”-20 HEX BOLTS | 1 – HOOD SEAL |
| 2 – ¼”-20 NYLOC NUTS | 1 – VACUUM CAP |

TOOLS REQUIRED:

- | | |
|--------------------------|-----------------------|
| 1 – FLAT SCREW DRIVER | 1 – 7/16” WRENCH |
| 1 – PHILIPS SCREW DRIVER | 1 – 9/16” WRENCH |
| 1 – DRILL MOTOR | 1 – ¼” DIAMETER DRILL |



1. First, disconnect mass air sensor from air box. Next, unclip upper filter housing, remove air pump hose and disconnect small vacuum line from manifold port. Cap port with supplied plug and remove filter housing top. Remove hot air tube between lower filter housing and exhaust heat shield. Remove rubber 'O' rings that hold air box to frame and remove lower filter housing.



2. Install mini-filter to air pump, if equipped.

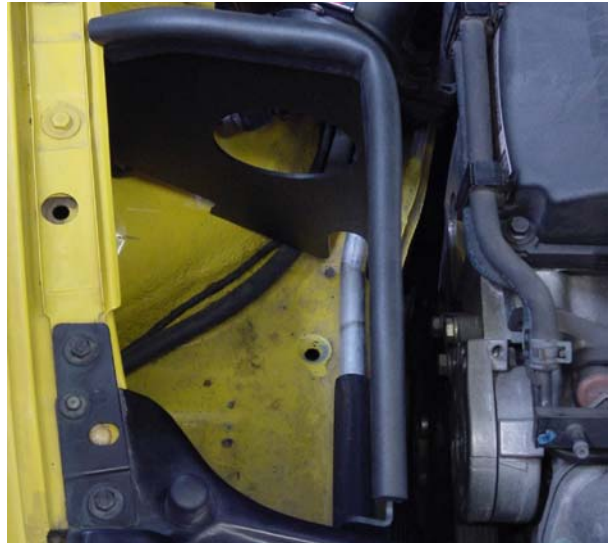

3. Insert lower front portion of the shield under the radiator support and slide bottom edge of shield into slot between AC condenser line and chassis seam. Rotate rear portion of shield down and into position, making sure any hoses and/or electrical lines are routed through cut outs.

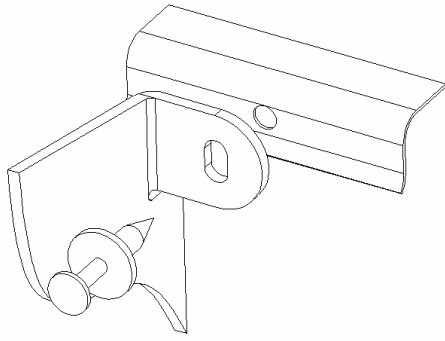

4. Due to slight variations in vehicle geometry (see illustration above), it is necessary to drill the radiator support to properly mount the heat shield. Pull the heat shield forward (towards the front of the car) until the mounting tab contacts the radiator support. Using the front mounting tab hole (slotted) as a guide, mark and center punch the radiator support.



5. Remove the head shield and drill a \varnothing 1/4" hole through the radiator support.



6. Install the heat shield and secure in front with the supplied push fastener and at the side with the supplied sheet metal screw as shown.



7. Mount mass air sensor to heat shield using supplied 1/4" bolts and lock nuts. Install air filter on mass air sensor and tighten hose clamp. **NOTE: Check tightness of clamp in one week.**

8. Carefully double-check complete installation. **TEST DRIVE CAREFULLY.**